

INSTRUCTIONS

INSTALLATION – COMPRESSOR RISER-MOUNT KIT

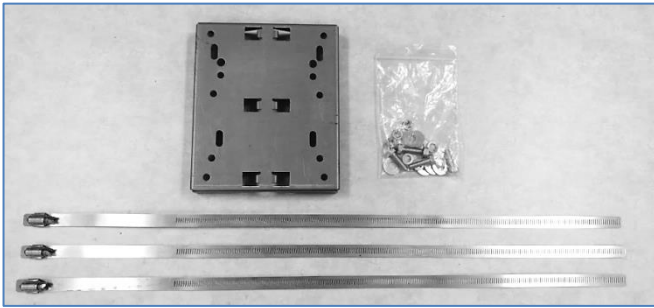

RISER-MOUNT KIT CONTENTS:

A) MOUNTING STRAPS: Each Riser-Mount Kit comes with 3 mounting straps.

B) RISER-MOUNT BRACKET: Slots allow for hassle-free mounting.

C) NUTS, BOLTS & WASHERS: Needed for mounting compressor to bracket (kit includes 4 bolts, 4 lock nuts, 4 lock washers, 8 washers.)

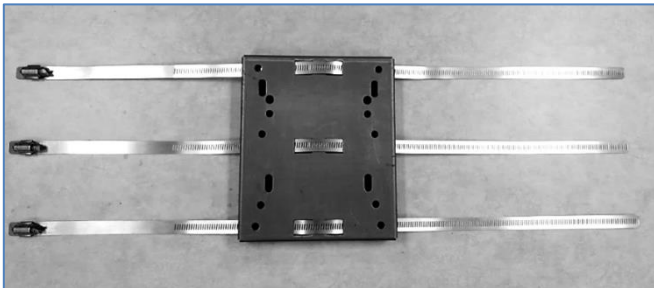

Bring the mounting straps in from the back side through the left hole, pass over the front of the plate and insert strap through the right hole, as shown. Repeat for straps 2 & 3.

NOTE: Once the straps are threaded into the mounting bracket, UFS recommends installing the bracket onto the riser. Ensure clamp 1 is on top and that all three clamps are tight against the riser (no slack).



After the mounting bracket is properly mounted on the riser, use the hardware provided to permanently secure the compressor to the compressor bracket. Straps must be 90° angles to riser for proper installation

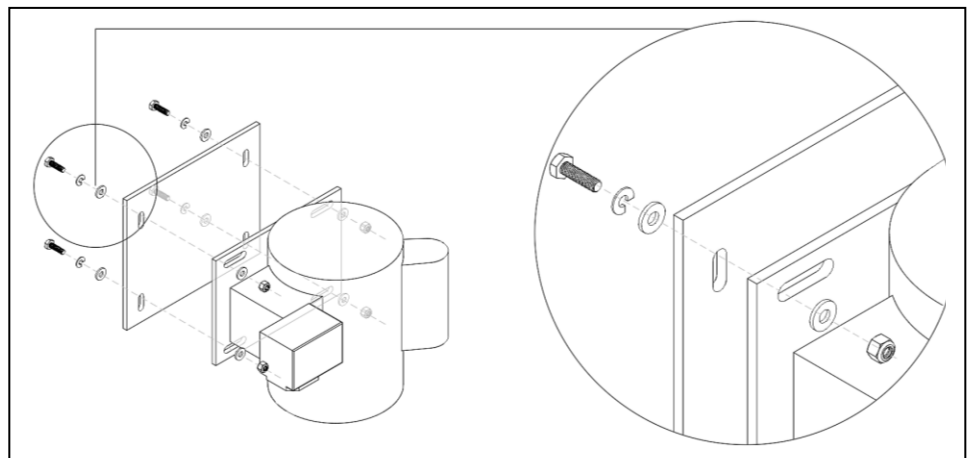

IMPORTANT NOTES:

- 1- Torque strap screws to 35-40 in-lbs.
- 2- UFS highly recommends that the compressor be mounted to the riser with the discharge port pointing down (as shown).
- 3- All hardware supplied with the mounting kit must be used to secure the compressor to the compressor bracket.
Failure to do so may void warranty!

UNITED Fire Systems

Division of United Fire Protection Corporation
1 MARK ROAD
KENILWORTH, NJ 07033 USA
PHONE: 908-688-0300 FAX: 908-688-0218
www.unitedfiresystems.com