

#### Filter/Regulator B74G-6AK- AD1-RMG

Port	Thread Form	Adjustment	Drain	Bowl	Element	Diaphragm	Spring (Outlet Pressure Range) *	Gauge
3....3/8"	A....PTF	K....Knob	A....Automatic	D....Metal with liquid level indicator	1....5 µm	N....Non-relieving	F....0.3 to 4 bar (5 to 60 psig)	G....With
4....1/2"	B....ISO Rc taper	T....T-bar	Q....Manual, 1/4 turn	P....Transparent with guard	2....25 µm	R....Relieving	M....0.3 to 10 bar (5 to 150 psig)	N....Without
6....3/4"	G....ISO G parallel				3....40 µm		S....0.7 to 17 bar (10 to 250 psig)	

\* Outlet pressure can be adjusted to pressures in excess of, and less than, those specified. Do not use these units to control pressures outside of the specified ranges.

#### TECHNICAL DATA

Fluid: Compressed air  
 Maximum pressure:  
 Transparent bowl: 10 bar (150 psig)  
 Metal bowl: 17 bar (250 psig)  
 Operating temperature\*:  
 Transparent bowl: -20° to +50°C (0° to +125°F)  
 Metal bowl: -20° to +80°C (0° to +175°F)  
 \* Air supply must be dry enough to avoid ice formation at temperatures below +2°C (+35°F).  
 Particle removal: 5 µm, 25 µm, or 40 µm filter element  
 Air quality: Within ISO 8573-1, Class 3 and Class 5 (particulates)  
 Typical flow with 10 bar (150 psig) inlet pressure, 6,3 bar (90 psig) set pressure and 1 bar (15 psig) droop from set: 100 dm<sup>3</sup>/s (212 scfm)  
 Nominal bowl size: 0,2 litre (7 fluid ounce)  
 Manual drain connection: 1/8"  
 Automatic drain connection: 1/8"  
 Automatic drain operating conditions (float operated):  
 Bowl pressure required to close drain: Greater than 0,3 bar (5 psig)  
 Bowl pressure required to open drain: Less than 0,2 bar (3 psig)  
 Minimum air flow required to close drain: 1 dm<sup>3</sup>/s (2 scfm)  
 Manual operation: Depress pin inside drain outlet to drain bowl  
 Gauge ports:  
 1/4 PTF with PTF main ports  
 Rc1/4 with ISO Rc main ports  
 Rc1/8 with ISO G main ports  
 Materials:  
 Body: Aluminum  
 Bonnet: Aluminum  
 Valve: Brass  
 Bowl:  
 Transparent with guard: Polycarbonate, steel guard  
 Metal: Aluminum  
 Metal bowl liquid level indicator lens: Transparent nylon  
 Element: Sintered polypropylene  
 Elastomers: Neoprene and nitrile

#### REPLACEMENT ITEMS

Service Kit (includes items circled in exploded view):  
 Relieving.....4383-700  
 Liquid level lens kit (34, 36, 37, 38) .....4380-050  
 Filter element, 5µm, red speckles (52).....4338-04  
 Automatic drain (21, 22, 23) (31, 32, 33)  
 1/8 NPT outlet .....3000-10  
 Tamper resistant cover (knob adjustment only).....4355-51

#### PANEL MOUNTING DIMENSIONS

Panel mounting hole diameter: 52 mm (2.06")  
 Panel thickness: 2 to 6 mm (0.06" to 0.25")

#### INSTALLATION

- Shut off air pressure. Install filter/regulator in air line -
  - vertically (bowl down),
  - with air flow in direction of arrow on body,
  - upstream of lubricators and cycling valves,
  - as close as possible to the device being serviced.
- Connect piping to proper ports using pipe thread sealant on male threads only. Do not allow sealant to enter interior of unit.
- Push bowl, or bowl with guard, into body and turn fully clockwise before pressurizing.
- Flexible tube with 3mm (0.125") minimum I.D. can be connected to the automatic drain. Avoid restrictions in the tube.
- Install a pressure gauge or plug the gauge ports. Gauge ports can also be used as additional outlets for regulated air.

#### ADJUSTMENT

- Before applying inlet pressure to filter/regulator, turn adjustment (1 or 7) counterclockwise to remove all force on regulating spring.
- Apply inlet pressure, then turn adjustment (1 or 7) clockwise to increase and counterclockwise to decrease pressure setting.
- Always approach the desired pressure from a lower pressure. When reducing from a higher to a lower setting, first reduce to some pressure less than that desired, then bring up to the desired pressure.

#### NOTE

With non-relieving filter/regulators, make pressure reductions with some air flow in the system. If made under no flow (dead-end) conditions, the filter/regulator will trap the over-pressure in the downstream line.  
 4. KNOB ADJUSTMENT. Push knob down to lock pressure setting. Pull knob up to release. Install tamper resistant cover (see **Replacement Items**) to make setting tamper resistant.

#### SERVICING

- Open manual drain to expel accumulated liquids. Keep liquids below baffle (51).
- Clean or replace filter element when dirty.

#### DISASSEMBLY

- Filter/regulator can be disassembled without removal from air line.
- Shut off inlet pressure. Reduce pressure in inlet and outlet lines to zero.
- Turn adjustment (1 or 7) fully counterclockwise.
- Remove bowl - push into body and turn counterclockwise.
- Disassemble in general accordance with the item numbers on exploded view. Do not remove the drains unless replacement is necessary. Remove and replace only if they malfunction.

#### CLEANING

- Clean plastic bowl (25, 42) with warm water only. Clean other parts with warm water and soap.
- Rinse and dry parts. Blow out internal passages in body (16) with clean, dry compressed air. Blow air through filter element (52) from inside to outside to remove surface contaminants.
- Inspect parts. Replace those found to be damaged. Replace plastic bowl with a metal bowl if plastic bowl shows signs of cracking or cloudiness.

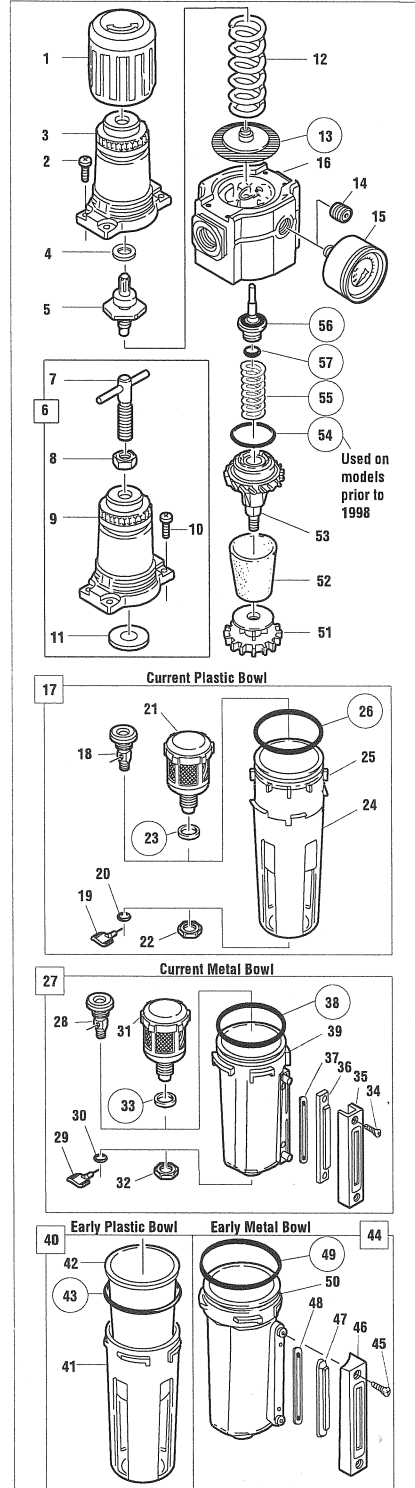

### ASSEMBLY

- Lubricate the following items with o-ring grease.
  - (Thrust washer) - outer circumference and both sides.
  - (Adjusting screw) - threads and tip.
  - (Manual drain body) - the portion of the body that contacts the bowl, and the hole that accommodates the stem of drain valve (19, 29).
  - (Valve) - stem.
  - (O-rings)
- Assemble the unit as shown on the exploded view. Push bowl, or bowl with guard, into body and turn fully clockwise.
- Torque Table
 

Item	Torque in Nm (Inch-Pounds)
2, 10 (Screw)	2,3 to 3,9 (20 to 35)
22, 32 (Nut)	2,3 to 2,8 (20 to 25)
34, 45 (Screw)	1,7 to 2,3 (15 to 20)
53 (Center-post)	2,0 to 2,7 (18 to 24)

### CAUTION

Water vapor will pass through these units and could condense into liquid form downstream as air temperature drops. Install an air dryer if water condensation could have a detrimental effect on the application.

### WARNING

These products are intended for use in industrial compressed air systems only. Do not use these products where pressures and temperatures can exceed those listed under **Technical Data**.

Polycarbonate plastic bowls can be damaged and possibly burst if exposed to such substances as certain solvents, strong alkalis, compressor oils containing ester-based additives or synthetic oils. Fumes of these substances in contact with the polycarbonate bowl, externally or internally, can also result in damage. Clean with warm water only.

Use metal bowl in applications where a plastic bowl might be exposed to substances that are incompatible with polycarbonate.

If outlet pressure in excess of the filter/regulator pressure setting could cause downstream equipment to rupture or malfunction, install a pressure relief device downstream of the filter/regulator. The relief pressure and flow capacity of the relief device must satisfy system requirements.

The accuracy of the indication of pressure gauges can change, both during shipment (despite care in packaging) and during the service life. If a pressure gauge is to be used with these products and if inaccurate indications may be hazardous to personnel or property, the gauge should be calibrated before initial installation and at regular intervals during use.

Before using these products with fluids other than air, for non industrial applications, or for life-support systems consult Norgren.

