



# PREACTION PAC

## SPRINKLER VALVE ASSEMBLY

# with Integrated Nitrogen

## INSTALLATION, COMMISSIONING, AND MAINTENANCE SUPPLEMENT

Serial Number \_\_\_\_\_

Date of Installation \_\_\_\_\_ Date of Commissioning \_\_\_\_\_



**UNITED Fire Systems**

Division of UNITED Fire Protection Corporation

1 Mark Road

Kenilworth, NJ USA 07033

908-688-0300

[www.unitedfiresystems.com](http://www.unitedfiresystems.com)

Supplement Part Number 10-50008-001

Revision 1.06

December 2024

**(THIS SURFACE DELIBERATELY LEFT BLANK)**

# INDEX

Section	Description	Page
	Index	i
	List Of Figures	ii
	List Of Tables	ii
	Foreword	iii
<b>1.</b>	<b>GENERAL INFORMATION</b>	<b>1</b>
1.1	System Purpose	1
1.2	About This Supplement	1
1.3	Assembly Description	1
1.3.1	<b>PREACTION-PAC™</b> Electrical Enclosure	1
1.3.2	<b>PREACTION-PAC™</b> Valve Enclosure	1
1.3.3	<b>NITROGEN-PAC™</b> Enclosure	1
1.3.4	Model <b>NR-5</b> Nitrogen Receiver	1
1.3.5	Model <b>NAMD-1</b> Pressure Maintenance Device	1
1.3.6	Other Items Included	3
<b>2.</b>	<b>EQUIPMENT SELECTION</b>	<b>3</b>
2.1	Introduction	3
2.2	Steps To Follow	3
2.3	Information To Be Obtained During Survey	3
2.4	Selection of <b>PREACTION-PAC™ with Integrated Nitrogen</b> Assembly	6
2.5	Part Number Examples	7
2.5.1	Victaulic 2-1/2 Inch Single Interlock Valve with Potter ARC-100 Control Panel	7
2.5.2	Tyco 4 Inch Double Interlock Valve with Notifier NFS2-640 Control Panel	7
2.6	Nitrogen Purging and Sensing	8
2.6.1	Purge Vent Assembly - Model <b>PVA</b>	8
2.6.2	Hand-Held N <sub>2</sub> Purity Analyzer - Model <b>NA-2</b>	8
2.6.3	(Optional) <b>TRUE ADVANCED PURGE™ (TAP)</b> Device - Model <b>TAP-G3</b>	8
2.6.4	(Optional) Corrosion Monitor Assembly - Model <b>CMA-1</b>	8
2.7	Typical Bills Of Material	9
<b>3.</b>	<b>INSTALLATION AND COMMISSIONING</b>	<b>10</b>
3.1	Assembly Dimensions	10
3.2	Installation	11
3.2.1	Applicable Sections of <b>PREACTION-PAC™</b> Manual	11
3.2.2	Applicable Sections of <b>NITROGEN-PAC™</b> Model <b>SC-W</b> Manual	11
3.2.3	Clearances	11

**UNITED FIRE SYSTEMS**  
**PREACTION-PAC™ WITH INTEGRATED NITROGEN**  
 INSTALLATION, COMMISSIONING, AND MAINTENANCE SUPPLEMENT  
 P/N 10-500008-001 REV 1.06 - DEC 2024

3.2.4	Power Supply Connection	12
3.2.4.1	Codes	12
3.2.4.2	Personnel	12
3.2.4.3	Power Supply Specification	12
3.2.4.4	Power Connection - Assemblies With Control Panel - One (1) Power Circuit	13
3.2.4.5	Power Connection - Assemblies With Control Panel - Two (2) Power Circuits	14
3.2.4.6	Power Connection - Assemblies Without Control Panel	15
3.2.4.7	Minimum Wire Size	15
3.2.4.8	Power For Accessories	16
3.2.5	<b>TRUE ADVANCED PURGE™</b> Model <b>TAP-G3</b> Manual	16
3.3	Commissioning	16
3.3.1	Applicable Section of <b>PREACTION-PAC™</b> Manual	16
3.3.2	Applicable Sections of <b>NITROGEN-PAC™</b> Model <b>SC-W</b> Manual	16
<b>4</b>	<b>INSPECTION, TESTING, AND MAINTENANCE</b>	16
4.1	Applicable Sections of <b>PREACTION-PAC™</b> Manual	16
4.2	Applicable Sections of <b>NITROGEN-PAC™</b> Model <b>SC-W</b> Manual	16

## LIST OF FIGURES

Figure No.	Description	Page
1	<b>PREACTION-PAC™</b> with Integrated Nitrogen	2
2	Assembly Dimensions	10
3	Required Clearances	11
4	Wiring Diagram - Assemblies With Control Panel - One (1) Power Circuit	13
5	Wiring Diagram - Assemblies With Control Panel - Two (2) Power Circuits	14
6	Wiring Diagram - Assemblies Without Control Panel	15

## LIST OF TABLES

Table No.	Description	Page
1	<b>PREACTION-PAC™</b> Installation, Operation, and Maintenance Manuals	3
2	Information To Be Obtained During Survey	5
3	Assembly Part Number Information	6
4	Purge Vent Assemblies	8
5	Assembly Dimensions	10
6	Required Clearances	12
7	Total Current Draw	12
8	Power Supply Connection Minimum Wire Size	15

## FOREWORD

This supplement is written for those who install, operate and maintain **UNITED Fire Systems PREACTION-PAC™** with Integrated Nitrogen sprinkler valve assemblies, and is meant to be used with the individual **PREACTION-PAC™** and **NITROGEN-PAC™** manuals included with the assembly.



### IMPORTANT

**UNITED Fire Systems** assumes no responsibility for the installation, operation, or maintenance of any systems other than those addressed in this supplement. The data contained in this supplement is for information purposes only.

**UNITED Fire Systems** believes this data to be accurate at the time of publication, but the data is published and presented without any guarantee or warranty whatsoever. **UNITED Fire Systems** disclaims any liability for any use that may be made of the data and information contained in this supplement by any and all parties.



### IMPORTANT

The **UNITED Fire Systems PREACTION-PAC™** with Integrated Nitrogen assembly is a vital part of the fire protection of any facility where these assemblies are installed. Life safety and property protection depends on continuing proper operation of the assembly. The owner of the assembly is responsible for the condition of the assembly and its continued proper operation. **UNITED Fire Systems** strongly recommends that all owners of **PREACTION-PAC™** with Integrated Nitrogen assemblies engage the services of qualified, trained fire protection professionals to design the system containing the assembly, and to install and maintain the assembly.

**UNITED Fire Systems PREACTION-PAC™** with Integrated Nitrogen assemblies are to be installed, operated, and maintained by qualified, trained personnel in accordance with:

- This Installation, Commissioning, and Maintenance Supplement **P/N 10-500008-001**
- Applicable **PREACTION-PAC™** Installation, Operation, and Maintenance Manual **P/N 10-50000X-00X**
- **NITROGEN-PAC™** Model **SC-W** Installation, Operation, and Maintenance Manual **P/N 30-NPWICM-000**
- National Fire Protection Association No. 13, "Standard for the Installation of Sprinkler Systems."
- National Fire Protection Association No. 25, "Standard for the Inspection, Testing, and Maintenance of Water-Based Fire Protection Systems."
- National Fire Protection Association No. 70, "National Electrical Code®".
- National Fire Protection Association No. 72, "National Fire Alarm Code®".

Any questions on the information in this supplement should be addressed to:

**UNITED Fire Systems**  
Division of United Fire Protection Corporation  
1 Mark Road  
Kenilworth, NJ USA 07033  
(908) 688-0300

## 1. GENERAL INFORMATION

**1.1 System Purpose.** The **UNITED Fire Systems PREACTION-PAC™** with Integrated Nitrogen is a fully assembled and factory tested preaction fire suppression system, including preaction valve, trim, optional control panel, and integrated nitrogen generator providing one complete zone of preaction water sprinkler fire protection. The system pressure gauges and the required manual release handle are mounted on the front of the valve enclosure. The optional control panel is mounted behind a door in the electrical enclosure with a clear polycarbonate window allowing visual access to the system indicators. The integrated nitrogen generator introduces high-purity nitrogen into the preaction system piping.

**1.2 About This Supplement.** This document serves to supplement the information contained in the separate **PREACTION-PAC™** and **NITROGEN-PAC™** manuals supplied with the integrated assembly. Refer to each of these manuals as referenced in this supplement. Ensure that each of the proper manuals is available.

**1.3 Assembly Description.** Refer to **Figure 1**. The assembly consists of a **PREACTION-PAC™** assembly with a **NITROGEN-PAC™** Model **SC-W** nitrogen generator assembly permanently attached, connected, and wired to the **PREACTION-PAC™**. Also included is a Model **NR-5** Nitrogen Receiver factory-mounted to the **PREACTION-PAC™** sprinkler riser outlet pipe, and a Model **NAMD-1** Pressure Maintenance Device factory-mounted in the **PREACTION-PAC™** lower enclosure.

**1.3.1 PREACTION-PAC™ Electrical Enclosure.** This enclosure contains the (optional) detection control panel and the terminal strip for field connection of 120 VAC 60 Hz single-phase power to the assembly. Refer to the Functional Description section of the applicable **PREACTION-PAC™** manual (see **Table 1**) and Section 3.2.3 of this supplement for additional information.

**1.3.2 PREACTION-PAC™ Valve Enclosure.** Refer to the Functional Description section of the applicable **PREACTION-PAC™** manual (see **Table 1**) for additional information.

**a. Interior.** This enclosure contains the preaction valve and all trim to make up a complete preaction system riser. The waterflow, low / high air, and tamper switches, and also the actuation solenoid, are all factory-wired to the terminal strip in the electrical enclosure. A Model **NAMD-1** Pressure Maintenance Device is located within the enclosure.

**b. Exterior.** The manual release valve is located behind a small non-locking door, and the preaction system pressure gauges are mounted to be visible without needing to open the main enclosure door.

**1.3.3 NITROGEN-PAC™ Model SC-W Enclosure.**

**a. Interior.** This enclosure contains the components needed to generate dried, filtered compressed air for separation of 98% purity nitrogen by the separator membrane. The enclosure interior also contains the nitrogen bypass valve, which places the **NITROGEN-PAC™** into **NORMAL** or **BYPASS** mode. Refer to Section 1.4 of Model **SC-W** Manual P/N 30-NPWICM-000 for additional information.

**b. Exterior.** The exterior of the enclosure contains various controls and indicators for the **NITROGEN-PAC™** system. Refer to Section 1.5 of the Model **SC-W** manual P/N 30-NPWICM-000 for additional information.

**1.3.4 Model NR-5 Nitrogen Receiver.** The Model **NR-5** Nitrogen Receiver is a steel 5 gallon tank for receiving and storing nitrogen from the Model **SC-W** assembly, and minimizes the Model **SC-W** assembly compressor runtime by providing a reservoir of nitrogen for the sprinkler system. The nitrogen receiver is factory-mounted to the **PREACTION-PAC™** sprinkler riser outlet pipe, and is connected to receive nitrogen from the **NITROGEN-PAC™** assembly and supply nitrogen to the Model **NAMD-1** Pressure Maintenance Device. Refer to Section 1.6 of the Model **SC-W** manual P/N 30-NPWICM-000 for additional information.

**1.3.5 Model NAMD-1 Pressure Maintenance Device.** The **FM Approved** Model **NAMD-1** Pressure Maintenance Device controls the nitrogen and / or air pressure from the Model **NR-5** nitrogen receiver into the sprinkler valve. The device is factory-mounted within the **PREACTION-PAC™** valve enclosure and is factory connected to the Model **NR-5** Nitrogen Receiver. Refer to Section 1.8 of the Model **SC-W** manual P/N 30-NPWICM-000 for additional information.



**Figure 1 - PREACTION-PAC™ with Integrated Nitrogen**

**UNITED FIRE SYSTEMS**  
**PREACTION-PAC™ WITH INTEGRATED NITROGEN**  
 INSTALLATION, OPERATION, AND MAINTENANCE SUPPLEMENT  
 P/N 10-500008-001 REV 1.06 – DEC 2024

**1.3.6 Other Items Included.**

**a. PREACTION-PAC™ manual** (part number based on model of **PREACTION-PAC™** - Refer to **Table 1**).

Control Panel	Valve Manufacturer and Type				Notes
	Victaulic		Tyco		
	Preaction Single Interlock and Double Interlock Elec / Elec <sup>2</sup>	Preaction Double Interlock Pneu / Elec <sup>3</sup>	Preaction Single Interlock and Double Interlock Elec / Elec <sup>2</sup>	Preaction Double Interlock Pneu / Elec <sup>3</sup>	
Potter PFC-4410 <sup>1</sup>	10-500001-00A		10-500002-00A	10-500003-00A	Discontinued
Notifier NFS2-640	10-500001-00B		10-500002-00B	10-500003-00B	
Notifier RP-2001 <sup>1</sup>	10-500001-00C		10-500002-00C	10-500003-00C	Discontinued
Fenwal FN-6000 <sup>1</sup>	10-500001-00D		10-500002-00D	10-500003-00D	Discontinued
Kidde ARIES-SLX	10-500001-00E		10-500002-00E	10-500003-00E	
Potter ARC-100	10-500001-00F		10-500002-00F	10-500003-00F	
Potter 4410G3	10-500001-00G		10-500002-00G	10-500003-00G	
No Panel	10-500001-00N		10-500002-00N	10-500003-00N	
<b>NOTES</b>					
<sup>1</sup> Control panel discontinued by manufacturer – information provided for reference only.					
<sup>2</sup> Double interlock Elec / Elec refers to valve operation upon control panel receipt of signal from fire detector and supervisory signal from low air pressure switch.					
<sup>2</sup> Double interlock Pneu / Elec refers to valve operation upon control panel receipt of signal from fire detector plus pressure loss sensed by pneumatic actuator connected to valve trim.					

**Table 1 – PREACTION-PAC™**  
 Installation, Operation, and Maintenance Manuals

**b. NITROGEN-PAC™ Model SC-W manual** (part number 30-NPWICM-000).

**c. N<sub>2</sub> Purity Analyzer - Model NA-2.** The Model **NA-2** hand-held N<sub>2</sub> purity analyzer is designed to permit manual verification of the N<sub>2</sub> purity at either the Model **SC-W** assembly N<sub>2</sub> purity analyzer connection point or at a Model **PVA-4** purge vent assembly. Occasional verification at the Model **SC-W** assembly provides assurance that the device is performing as intended. Verification at the purge vent assembly provides assurance that 98% N<sub>2</sub> purity is present in the sprinkler piping. Qty. (1) Model **NA-2** analyzer is included with each **PREACTION-PAC™** with Integrated Nitrogen assembly. Refer to Section 1.10 of the Model **SC-W** manual P/N 30-NPWICM-000 for additional information.



## 2. EQUIPMENT SELECTION

**2.1 Introduction.** This section outlines the steps to determine the equipment to be selected for the **PREACTION-PAC™** with Integrated Nitrogen system, and supplements the information in the applicable **PREACTION-PAC™** manual (refer to **Table 1**) and Section 2 of the **NITROGEN-PAC™** Model **SC-W** manual P/N 30-NPWICM-000.

### 2.2 Steps to Follow.

- (a) Read, understand, and follow the instructions in this supplement.
- (b) Perform a survey of the sprinkler system to be supplied with nitrogen.



### IMPORTANT

The **PREACTION-PAC™** with Integrated Nitrogen assembly is designed to supply air and nitrogen **ONLY** to the preaction sprinkler system served by the valve in the **PREACTION-PAC™** valve. Do **NOT** attempt to use the **NITROGEN-PAC™** system for supplying air or nitrogen to additional sprinkler risers.



### IMPORTANT

The **PREACTION-PAC™** with Integrated Nitrogen assembly is designed to supply 30-minute initial-fill air from the air compressor contained within the **NITROGEN-PAC™** system. Do **NOT** attempt to alter the connection tubing within the **PREACTION-PAC™** valve enclosure to add an external air compressor. If an external air compressor is required for 30-minute initial fill, consider the use of separate **PREACTION-PAC™** and **NITROGEN-PAC™** assemblies.

- (c) Use survey information to determine that the **NITROGEN-PAC™** system that is integrated into the assembly is adequate for the preaction sprinkler system, and to choose all other components needed for a complete system.

### 2.3 Information To Be Obtained During Survey. Refer to **Table 2**.



### IMPORTANT

The pipe volume is a fundamental parameter that **MUST** be determined. If a relatively “inaccurate” method of determining length (such as “pacing off”) must be used, make sure that the pipe volume is not underestimated. Underestimating the pipe volume can result in:

1. Not meeting the 30-minute initial-fill requirement.
2. Greatly extended compressor run time, and shortened compressor life.
3. Not reaching or maintaining 98% nitrogen purity in the piping.
4. Not maintaining minimum pipe pressure, resulting in unwanted “low air” signals.

Refer to Section 2.6.2 in **NITROGEN-PAC™** Model **SC-W** manual P/N 30-NPWICM-000 for additional information.

**WHEN IN DOUBT, OVERESTIMATE!**

**UNITED FIRE SYSTEMS**  
**PREACTION-PAC™ WITH INTEGRATED NITROGEN**  
 INSTALLATION, COMMISSIONING, AND MAINTENANCE SUPPLEMENT  
 P/N 10-500008-001 REV 1.06 - DEC 2024

Item No.	Item	Result
1	Is only <b>one</b> sprinkler riser with a volume of no more than <b>500 gallons</b> to be supplied with air and nitrogen?	<b>YES</b> - Use <b>PREACTION-PAC™</b> with Integrated Nitrogen.
		<b>NO</b> - Choose other <b>UNITED Fire Systems</b> equipment, such as: <ul style="list-style-type: none"> <li>• <b>PREACTION-PACs</b> without integrated <b>NITROGEN-PACs</b>.</li> <li>• Other <b>NITROGEN-PAC™</b> system equipment.</li> </ul>
2	Is the sprinkler system <b>NEW</b> or <b>EXISTING</b> ?	<b>NEW</b> - Significant gas pressure leakage is not likely. The maximum leakage is 1-1/2 PSIG in 24 hours starting at 40 PSIG.
		<b>EXISTING</b> - Significant gas pressure leakage is likely. To ensure minimum compressor run time and lengthen compressor life, test for and correct leaks until total leakage is no more than 1-1/2 PSIG in 24 hours starting at 40 PSIG.
3	Is the sprinkler system equipped with a quick-opening device (dry accelerator)?	<b>YES</b> - The action of the dry accelerator during purging is important. To avoid inadvertent sprinkler valve tripping, consider replacing the dry accelerator with a new device, or close the inlet valve to the dry accelerator during purging.
		<b>NOTE:</b> Closing the dry accelerator inlet valve may result in lengthened time for water to reach the most remote sprinkler head(s). Ensure that the Authorities Having Jurisdiction and the owner are in agreement regarding closing the dry accelerator inlet valve.
		<b>NO</b> - No additional consideration is needed.
4	Will the sprinkler riser have <b>MANUAL</b> or <b>AUTOMATIC</b> N <sub>2</sub> purity sensing and purging?	<b>MANUAL</b> - No additional consideration is necessary.
		<b>AUTOMATIC</b> - Choose <b>TRUE ADVANCED PURGE™ Model TAP-G3</b> device.
5	Will the sprinkler riser need automatic corrosion monitoring?	<b>YES</b> - Include a Model <b>CMA-1</b> – Corrosion Monitor Assembly.
		<b>NO</b> - No additional consideration is necessary.
<p><b>NOTE:</b> The maximum supervisory pressure supplied by the <b>NITROGEN-PAC™ Model SC-W</b> assembly is <b>40 PSIG</b>. Both types of preaction sprinkler valve available in the <b>PREACTION-PAC™ with Integrated Nitrogen</b> assembly use approximately <b>15 PSIG</b>.</p>		

**Table 2 - Information To Be Obtained During Survey**

**UNITED FIRE SYSTEMS**  
**PREACTION-PAC™ WITH INTEGRATED NITROGEN**  
 INSTALLATION, COMMISSIONING, AND MAINTENANCE SUPPLEMENT  
 P/N 10-500008-001 REV 1.06 - DEC 2024

**2.4 Selection of PREACTION-PAC™ with Integrated Nitrogen Assembly.** The part number of the required assembly can be derived from **Table 3**.

GENERATION / VALVE MFR.																																																	
VALVE SIZE																																																	
SYSTEM TYPE																																																	
PRESSURE SOURCE																																																	
CONTROL PANEL																																																	
<b>GX</b>	<b>- XX</b>	<b>- XX</b>	<b>- XX</b>	<b>- X</b>																																													
<table border="1" style="width: 100%; border-collapse: collapse; margin-top: 10px;"> <thead> <tr> <th></th> <th>MFR</th> <th>MODEL</th> <th>TYPE</th> <th>STATUS</th> </tr> </thead> <tbody> <tr> <td>A</td> <td>POTTER</td> <td>4410-RC</td> <td>CONV</td> <td>DISCONTINUED</td> </tr> <tr> <td>B</td> <td>NOTIFIER</td> <td>NFS2-640</td> <td>ADDR</td> <td>CURRENT</td> </tr> <tr> <td>C</td> <td>NOTIFIER</td> <td>RP-2001</td> <td>CONV</td> <td>DISCONTINUED</td> </tr> <tr> <td>D</td> <td>FENWAL</td> <td>FN-6000</td> <td>ADDR</td> <td>DISCONTINUED</td> </tr> <tr> <td>E</td> <td>KIDDE</td> <td>ARIES-SLX</td> <td>ADDR</td> <td>CURRENT</td> </tr> <tr> <td>F</td> <td>POTTER</td> <td>ARC-100</td> <td>ADDR</td> <td>CURRENT</td> </tr> <tr> <td>G</td> <td>POTTER</td> <td>4410G3</td> <td>CONV</td> <td>CURRENT</td> </tr> <tr> <td>N</td> <td colspan="3">NO PANEL</td> <td>CURRENT</td> </tr> </tbody> </table>						MFR	MODEL	TYPE	STATUS	A	POTTER	4410-RC	CONV	DISCONTINUED	B	NOTIFIER	NFS2-640	ADDR	CURRENT	C	NOTIFIER	RP-2001	CONV	DISCONTINUED	D	FENWAL	FN-6000	ADDR	DISCONTINUED	E	KIDDE	ARIES-SLX	ADDR	CURRENT	F	POTTER	ARC-100	ADDR	CURRENT	G	POTTER	4410G3	CONV	CURRENT	N	NO PANEL			CURRENT
	MFR	MODEL	TYPE	STATUS																																													
A	POTTER	4410-RC	CONV	DISCONTINUED																																													
B	NOTIFIER	NFS2-640	ADDR	CURRENT																																													
C	NOTIFIER	RP-2001	CONV	DISCONTINUED																																													
D	FENWAL	FN-6000	ADDR	DISCONTINUED																																													
E	KIDDE	ARIES-SLX	ADDR	CURRENT																																													
F	POTTER	ARC-100	ADDR	CURRENT																																													
G	POTTER	4410G3	CONV	CURRENT																																													
N	NO PANEL			CURRENT																																													
NP INTEGRATED NITROGEN																																																	
P1 PREACTION SINGLE INTERLOCK =OR= DOUBLE INTERLOCK ELEC / ELEC																																																	
P2 PREACTION DOUBLE INTERLOCK PNEU / ELEC																																																	
NOTE: See page 3 for explanation of Double Interlock Elec / Elec and Pneu / Elec.																																																	
			VICTAULIC	TYCO																																													
15			1-1/2 INCH	X																																													
20			2 INCH	X																																													
25			2-1/2 INCH	X																																													
30			3 INCH	X																																													
40			4 INCH	X																																													
60			6 INCH**	X																																													
G2	GEN 2 - VICTAULIC VALVE																																																
G3	GEN 3 - TYCO VALVE																																																
** 6 Inch valve is not FM Approved.																																																	

**Table 3 - Assembly Part Number Information**

**2.5 Part Number Examples.**

**2.5.1** Victaulic 2-1/2 inch single interlock sprinkler valve with Potter ARC-100 control panel:

				GENERATION / VALVE MFR.		
				VALVE SIZE		
				SYSTEM TYPE		
				PRESSURE SOURCE		
				CONTROL PANEL		
<b>G2</b>	<b>- 25 -</b>	<b>P1 -</b>	<b>NP -</b>	<b>F</b>		
				F	POTTER ARC-100	
			NP		INTEGRATED NITROGEN	
		P1			PREACTION SINGLE INTERLOCK	
					VICTAULIC	TYCO
	25				2-1/2 INCH	X
G2					GEN 2 - VICTAULIC VALVE	

**2.5.2** Tyco 4 inch double interlock sprinkler valve with Notifier NFS2-640 control panel.

				GENERATION / VALVE MFR.		
				VALVE SIZE		
				SYSTEM TYPE		
				PRESSURE SOURCE		
				CONTROL PANEL		
<b>G3</b>	<b>- 40 -</b>	<b>P2 -</b>	<b>NP -</b>	<b>B</b>		
				B	NOTIFIER NFS2-640	
			NP		INTEGRATED NITROGEN	
		P2			PREACTION DOUBLE INTERLOCK	
					VICTAULIC	TYCO
	40				4 INCH	X
G3					GEN 3 - TYCO VALVE	

**2.6. Nitrogen Purging and Sensing.**

**2.6.1 Purge Vent Assembly - Model PVA.** Each sprinkler system requires the installation of a purge vent assembly (PVA) to permit replacement of air within each system with nitrogen. The purge vent assembly includes a manual shutoff valve and an automatic float valve to prevent water discharge when the sprinkler system fills with water. Each model of PVA includes the proper orifice for purging and the proper outlet connection for the nitrogen purity monitoring method chosen. Choose the proper model of purge vent assembly (Model **PVA**) per **Table 4**.

Model	Description	Outlet Connection
<b>PVA-2</b>	For use on systems with <b>TRUE ADVANCED PURGE™ (TAP)</b> Device	Push-on tubing
<b>PVA-4</b>	For use on systems with Hand-Held N <sub>2</sub> Purity Analyzer	Female quick-connect
<b>(PVA-1)</b>	<b>DO NOT</b> use Model <b>PVA-1</b> Purge Vent Assembly on <b>PREACTION-PAC™</b> with Integrated Nitrogen systems. This assembly is intended only for use with <b>NITROGEN-PAC™ M Series</b> systems.	
<b>(PVA-3)</b>	<b>DO NOT</b> use Model <b>PVA-3</b> Purge Vent Assembly on <b>PREACTION-PAC™</b> with Integrated Nitrogen systems. This assembly is intended only for use with <b>NITROGEN-PAC™</b> Model <b>SC-1</b> and <b>SC-2</b> systems.	

**Table 4 - Purge Vent Assemblies**

**2.6.2 Hand-Held N<sub>2</sub> Purity Analyzer – Model NA-2.** The hand-held nitrogen purity analyzer Model **NA-2** is used to manually measure nitrogen purity at each Model **PVA-4** and at the N<sub>2</sub> purity analyzer connection point on the Model **SC-W** assembly.

**2.6.3 (Optional) TRUE ADVANCED PURGE™ (TAP) Device – Model TAP-G3.**

- (a) TAP Device.** The **TRUE ADVANCED PURGE™ (TAP)** Device automatically measures the nitrogen purity in the sprinkler piping, and also automatically controls the required purge cycle. Choose one (1) **TAP** device per sprinkler riser where such automation is desired. NOTE: Choose Model **PVA-2** Purge Vent Assembly for use with each **TAP** device.
- (b) Connection Tubing.** The **TAP** device inlet is connected to the outlet of the Model **PVA-2** Purge Vent Assembly with plenum-rated polyethylene tubing. The device is shipped with twenty (20) feet of suitable tubing. Additional custom-cut lengths of tubing (P/N 33-000003-XXX) are available.
- (c) Connector, Tube x Tube.** Connector P/N 33-000006-000 is used to connect individual lengths of tubing together.

**2.6.4 (Optional) Corrosion Monitor Assembly – Model CMA-1.** The optional corrosion monitor assembly Model **CMA-1** may be installed to provide a signal when internal corrosion has occurred inside the sprinkler pipe.

**UNITED FIRE SYSTEMS**  
**PREACTION-PAC™ WITH INTEGRATED NITROGEN**  
 INSTALLATION, COMMISSIONING, AND MAINTENANCE SUPPLEMENT  
 P/N 10-500008-001 REV 1.06 - DEC 2024

**2.7 Typical Bills Of Material**

UFS P/N	Quantity	Description
G2-25-P1-NP-F	1	<b>PREACTION-PAC™ with Integrated Nitrogen</b> Assembly. Includes:
	1	Gen 2 (Victaulic) 2-1/2 Inch Single Interlock Preaction Valve
	1	Potter ARC-100 Addressable Control Panel
	1	<b>NITROGEN-PAC™</b> Model <b>SC-W</b> Nitrogen Generator
	1	Model <b>NR-5</b> Nitrogen Reservoir
	1	Model <b>NAMD-1</b> Pressure Maintenance Device
	1	Model <b>NA-2</b> Hand-Held N <sub>2</sub> Purity Analyzer
	1	Manual P/N 10-500001-00F
	1	Manual P/N 30-NPWICM-000
	1	Supplement P/N 10-500008-001
PVA-4	1	Purge Vent Assembly - Model <b>PVA-4</b>

UFS P/N	Quantity	Description
G3-40-P2-NP-B	1	<b>PREACTION-PAC™ with Integrated Nitrogen</b> Assembly. Includes:
	1	Gen 3 (Tyco) 4 Inch Double Interlock Preaction Valve
	1	Notifier NFS2-640 Addressable Intelligent Control Panel
	1	<b>NITROGEN-PAC™</b> Model <b>SC-W</b> Nitrogen Generator
	1	Model <b>NR-5</b> Nitrogen Reservoir
	1	Model <b>NAMD-1</b> Pressure Maintenance Device
	1	Model <b>NA-2</b> Hand-Held N <sub>2</sub> Purity Analyzer
	1	Manual P/N 10-500003-00B
	1	Manual P/N 30-NPWICM-000
	1	Supplement P/N 10-500008-001
PVA-2	1	Purge Vent Assembly - Model <b>PVA-2</b>
TAP-G3-115	1	True Advanced Purge™ Device - Model <b>TAP-G3</b>
33-000003-XXX	As Required	Connection Tubing (custom length)
CMA-1	1	Corrosion Monitor Assembly - Model <b>CMA-1</b>

### 3. INSTALLATION AND COMMISSIONING

#### 3.1 Assembly Dimensions. Refer to Figure 2 and Table 5.

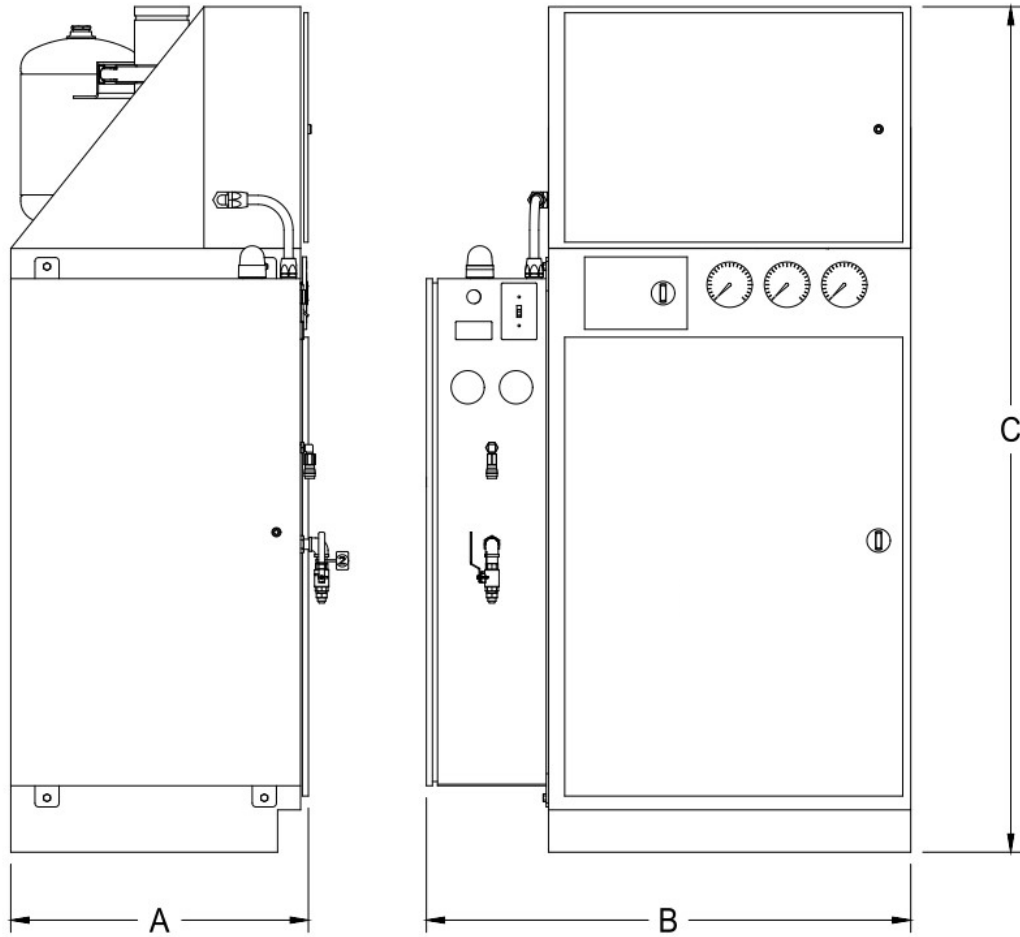

**Figure 2 - Assembly Dimensions (Control Panel option shown)**

Dimension	Length (inches)
A (depth)	25
B (width)	42
C (height)	70 (control panel option) 60 (no control panel option)

**Table 5**  
 Assembly Dimensions

### 3.2 Installation.

3.2.1 Refer to Section 1.10 of the applicable **PREACTION-PAC™** manual (see Table 1) for information on:

- (a) Assembly location.
- (b) Unpacking, placement, and leveling.
- (c) External attachments.

3.2.2 Refer to Section 3.2 of the **NITROGEN-PAC™** Model **SC-W** manual P/N 30-NPWICM-000 for information on:

- (a) Assembly location.
- (b) N<sub>2</sub> purity analyzer connection.
- (c) Drain connection.
- (d) Installation of Purge Vent Assembly - Model **PVA**.
- (e) N<sub>2</sub> Purity Analyzer - Model **NA-2**.
- (f) Installation of (optional) Corrosion Monitor Assembly - Model **CMA-1**.

3.2.3 **Clearances.** Refer to **Figure 3** and **Table 6**. In addition to the assembly location instructions in the manuals referenced in **3.2.1** and **3.2.2**, clearances specific to the **PREACTION-PAC™ with Integrated Nitrogen** must be observed and planned for at installation.

- (a) **Dimension A** is the clearance required at the back of the **PREACTION-PAC™ with Integrated Nitrogen** assembly for adequate cooling air flow into the **NITROGEN-PAC™** enclosure. Allow a minimum of 3 inches between the back of the assembly and the wall.
- (b) **Dimension B** is the clearance required for access to the interior of the **NITROGEN-PAC™** enclosure. Allow a minimum of 22 inches of clearance on the left side of the assembly to permit the door to be swung open fully. Additional clearance may be deemed necessary for ease of access during maintenance.
- (c) **Dimension C** is the clearance required for access to the interiors of the **PREACTION-PAC™** mechanical and electrical enclosures. Allow a minimum of 29 inches of clearance at the front of the assembly to permit the doors to be opened fully.

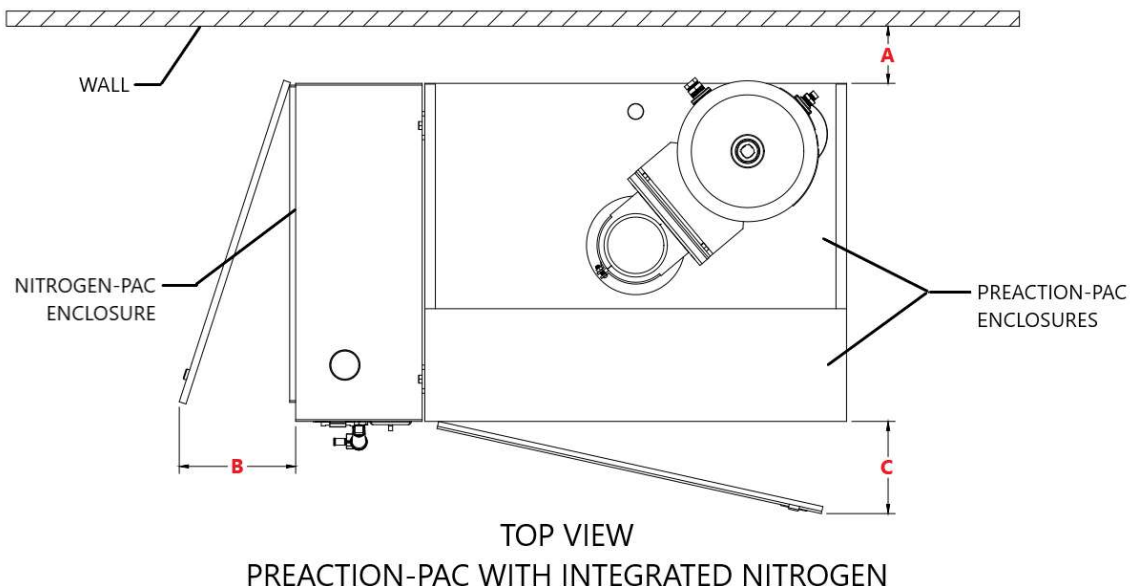

**Figure 3 – Required Clearances**



Dimension	Clearance Description	Minimum Distance (inches)
<b>A</b>	Back of Assembly for Cooling Air Flow	3
<b>B</b>	Left Side of Assembly for <b>NITROGEN-PAC™</b> Access	22
<b>C</b>	Front of Assembly for <b>PREACTION-PAC™</b> Access	29

**Table 6 – Required Clearances**

**3.2.4 Power Supply Connection.** The power connection terminals for the **PREACTION-PAC™** with Integrated Nitrogen are located on the terminal strip in the **PREACTION-PAC™** electrical enclosure.



**DANGER**

**RISK OF ELECTROCUTION**

**Voltages and currents associated with the PREACTION-PAC™ with Integrated Nitrogen assembly are LETHAL. Follow all instructions provided. Work involving electric power MUST be performed ONLY by qualified individuals. All required precautions to prevent contact with live electrical conductors MUST be taken. Failure to comply with these instructions is an immediate hazard with a likelihood of death or serious personal injury!**

**3.2.4.1 Codes.** All wiring and wiring methods shall be in strict compliance with NEC and local codes.

**3.2.4.2 Personnel.** All wiring shall be performed by a licensed electrician.

**3.2.4.3 Power Supply Specification.** The **PREACTION-PAC™** with Integrated Nitrogen assembly uses 120 VAC, 60 Hz, single phase, 3-wire (HOT, NEUTRAL, GROUND) power. Refer to **Table 7** for total current draw.

Control Panel	Total Current Draw (Panel and <b>NITROGEN-PAC™</b> ), Amps
Potter 4410-RC*	16.4
Notifier NFS2-640	18.0
Notifier RP-2001*	18.7
Fenwal FN-6000*	16.2
Kidde ARIES-SLX	16.2
Potter ARC-100	19.0
Potter 4410G3	16.2
No Control Panel	14.0
*Provided for reference only – panel discontinued.	

**Table 7 - Total Current Draw**

**3.2.4.4 Power Connection - Assemblies With Control Panel - One (1) Power Circuit.**

- Refer to **Figure 4**.
- Follow these instructions when the authority having jurisdiction permits the control panel and the **NITROGEN-PAC™** to share the 120 VAC power circuit.
- Leave factory-installed jumpers inserted in terminal blocks.
- Connect single power circuit to indicated terminals.
- Power will be supplied jointly to both the control panel and the **NITROGEN-PAC™**.

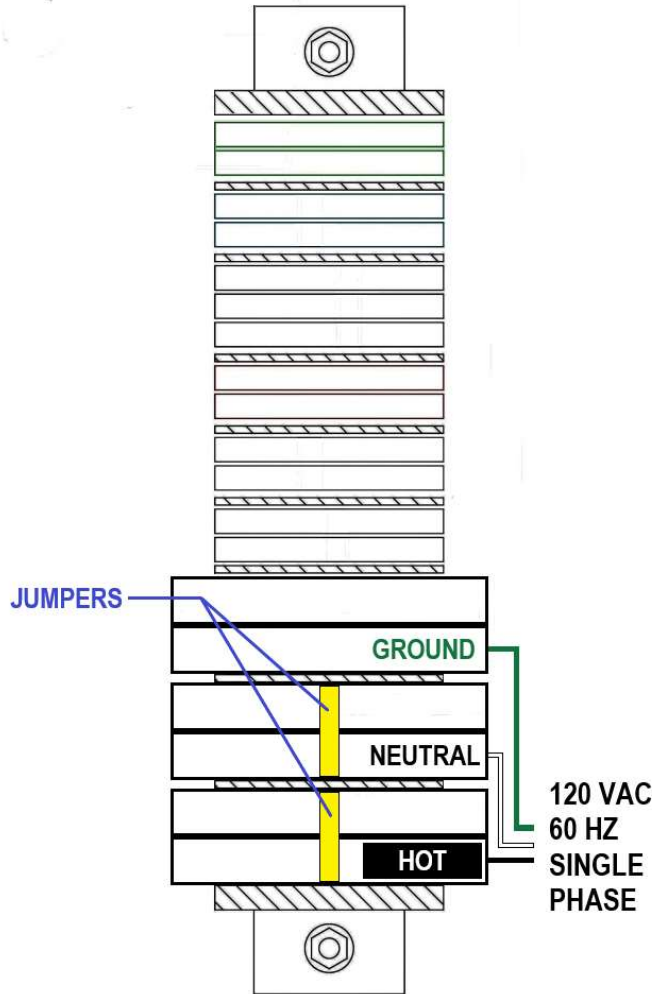

**Figure 4 - Wiring Diagram**  
Assemblies With Control Panel  
One (1) Power Circuit

**3.2.4.5 Power Connection - Assemblies With Control Panel - Two (2) Power Circuits**

- Refer to **Figure 5**.
- Follow these instructions when the authority having jurisdiction **DOES NOT** permit one (1) power circuit to supply both the control panel and the nitrogen system.
- Remove factory-installed jumpers from terminal blocks. Connect two (2) power circuits to indicated terminals. Power will be supplied separately to the control panel and the **NITROGEN-PAC™**.

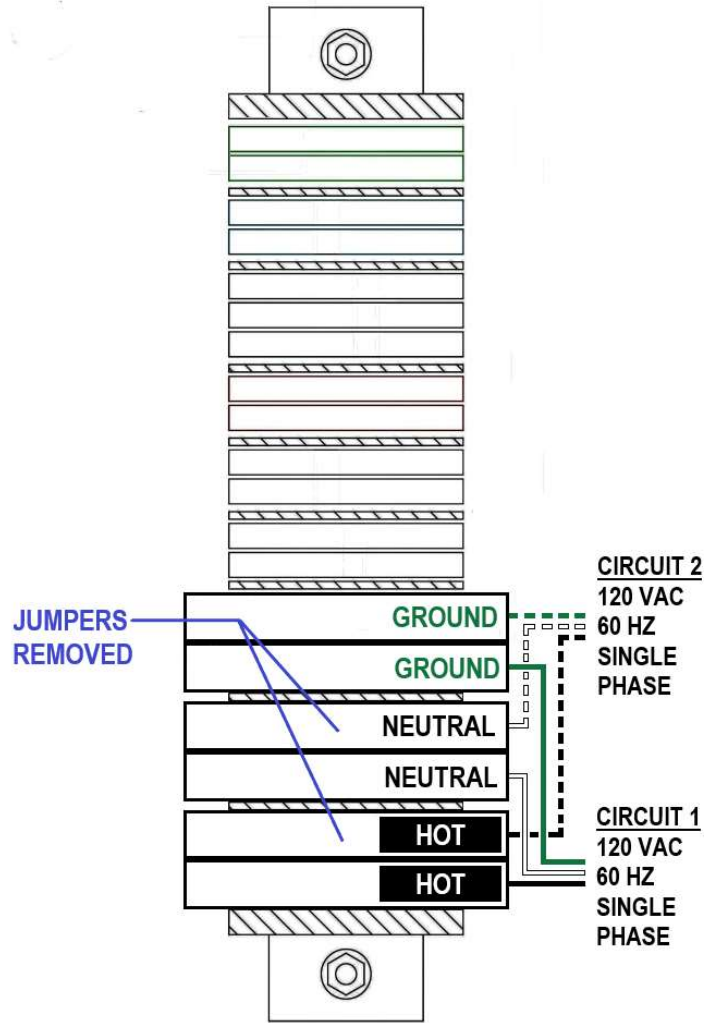

**3.2.4.6 Assemblies Without Control Panel.**

- Refer to **Figure 6**.
- Connect one (1) power circuit to indicated terminals. Power will be supplied to the **NITROGEN-PAC™**.

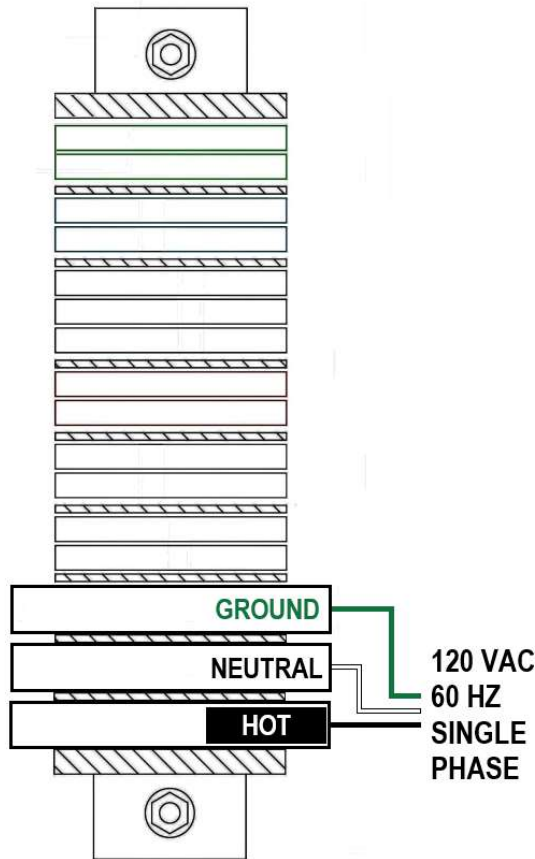

**Figure 6 - Wiring Diagram**  
 Assemblies Without Control Panel

**3.2.4.7 Minimum Wire Size. Refer to Table 8.**

LENGTH OF WIRE RUN FROM CIRCUIT BREAKER PANELBOARD TO ASSEMBLY	MINIMUM WIRE SIZE (AWG)
Less than 25 feet	<b>12 gauge</b> minimum
Over 25 feet up to 50 feet	<b>10 gauge</b> minimum
Over 50 feet up to 100 feet	<b>8 gauge</b> minimum ( <b>NOTE:</b> Terminal block in electrical enclosure accepts maximum 10 gauge wire. Use a <b>SHORT</b> piece of 10 gauge wire as a pigtail attached to the 8 gauge wire with a mechanical connection device (such as a wire nut) <b>WITHIN</b> electrical enclosure)
Over 100 feet	Use latest edition of NFPA 70, <i>National Electrical Code</i> , to determine ampacity of conductors to deliver <b>12 A</b> minimum at no less than 115 VAC (maximum 4% voltage drop from nominal 120 VAC) under full load.

**Table 8 - Power Supply Connection**  
 Minimum Wire Size

**3.2.4.8 Power for Accessories.** **UNITED Fire Systems** recommends that power for accessories (such as a condensate pump) be a separate wiring run from its own circuit breaker, and not be combined with the **PREACTION-PAC™** with Integrated Nitrogen assembly power or connected to the **PREACTION-PAC™** with Integrated Nitrogen assembly terminal strip.

**3.2.5** Refer to manual **P/N 33-TG3MAN-000** for installation of (optional) **TRUE ADVANCED PURGE™** Model **TAP-G3** device.

### **3.3 Commissioning.**

**3.3.1** Refer to Section 1.10.6 of the applicable **PREACTION-PAC™** manual (see **Table 1**) for information on placing the **PREACTION-PAC™** portion of the assembly into service.

**3.3.2** Refer to Section 4 of the **NITROGEN-PAC™** Model **SC-W** manual for information on commissioning the **NITROGEN-PAC™** Model **SC-W** portion of the assembly. Also refer to Appendix C of the same manual for a commissioning checklist.

### **4. Inspection, Testing, and Maintenance.**

**4.1** Refer to Section 1.12 of the applicable **PREACTION-PAC™** manual (see **Table 1**) for information on inspection, testing, and maintenance of the **PREACTION-PAC™** portion of the assembly.

**4.2** Refer to Section 5 of the **NITROGEN-PAC™** Model **SC-W** manual for information on inspection, testing, and maintenance of the **NITROGEN-PAC™** Model **SC-W** portion of the assembly. For checklists, refer to:

- (a) Appendix D - Monthly Inspection.
- (b) Appendix E - Annual Maintenance.

**(THIS SURFACE DELIBERATELY LEFT BLANK)**



**UNITED Fire Systems**

Division of UNITED Fire Protection Corporation

1 Mark Road

Kenilworth, NJ USA 07033

908-688-0300

[www.unitedfiresystems.com](http://www.unitedfiresystems.com)